

REV.	DATE	BY	ECN	REMARKS	CK
					-

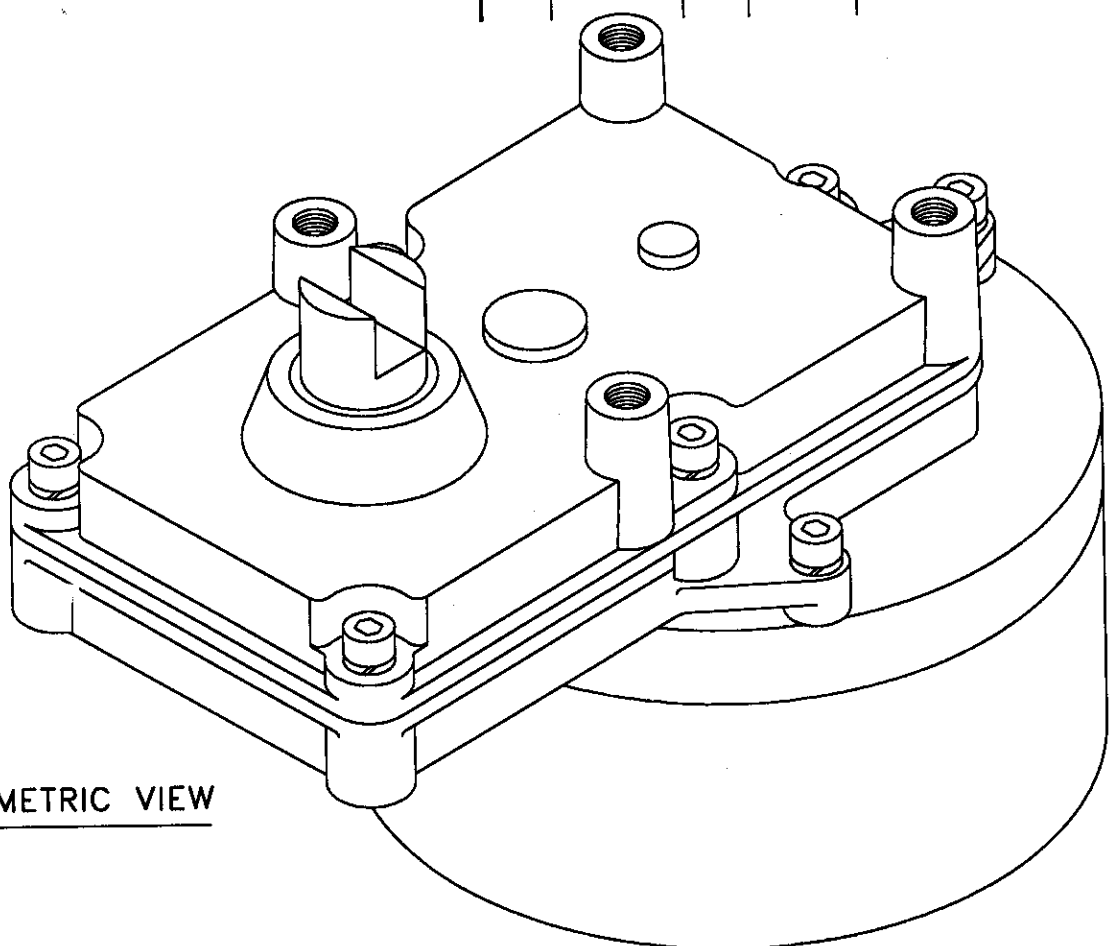

ISOMETRIC VIEW

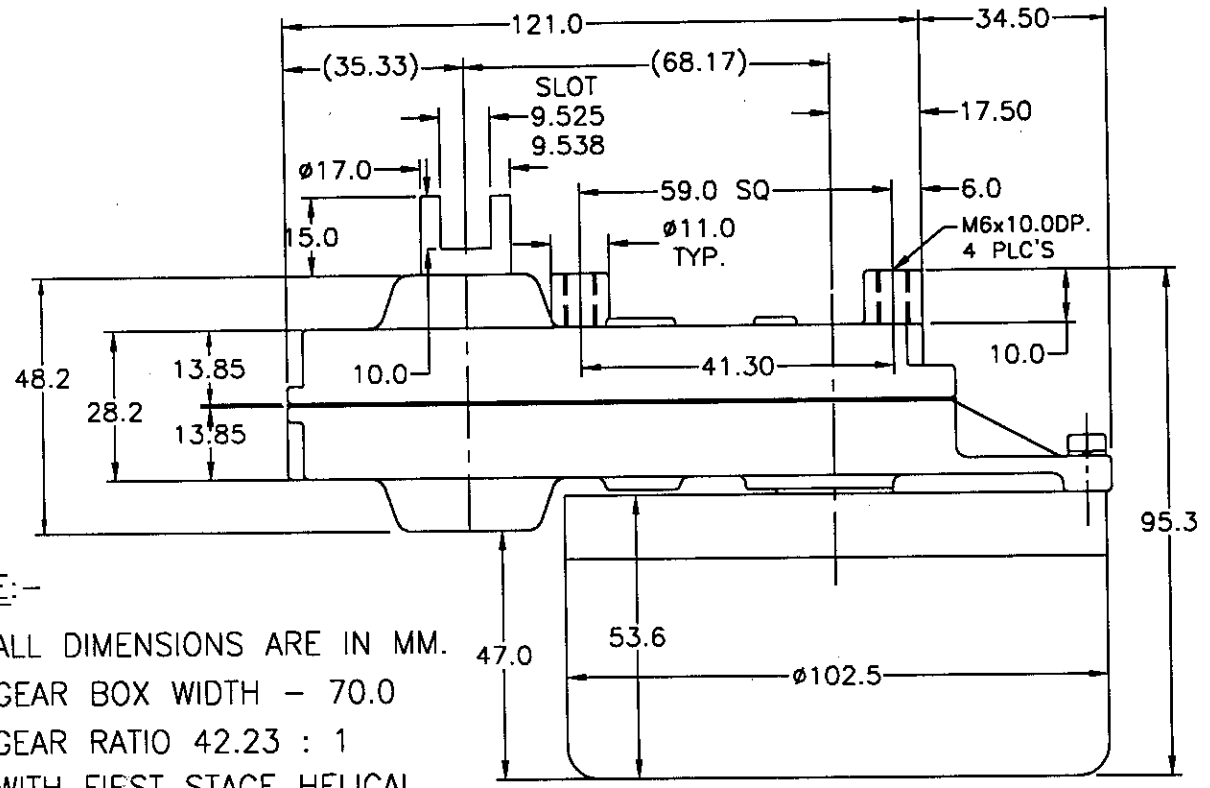

NOTE:-

1. ALL DIMENSIONS ARE IN MM.
2. GEAR BOX WIDTH - 70.0
3. GEAR RATIO 42.23 : 1
WITH FIRST STAGE HELICAL
4. USE HIGH TEMPERATURE
NON MIGRATING GREASE

SCALE:-0.7:1

TOLERANCE UNLESS SPECIFIED .0 ±.25 .00 ±.13	ANGULARITY CIRCULAR RUNOUT CONCENTRICITY PERPENDICULARITY (X) REFERENCE DIM. DIAMETER	DRAWN BY: PARTH	BMC BRUSHLESS MOTOR CO. 7625 Haverhurst Ave., Suite 34, Van Nuys, CA 91406, USA.
		CHECKED BY: SGN	
MATERIAL:-	DATE: 03 APRIL 03	13070C	REV.

NOTE: THIS IS CONFIDENTIAL PROPERTY OF BMC. IT IS NOT TO BE COPIED OR DUPLICATED IN ANY MANNER AND SHALL NOT BE SUBMITTED TO OUTSIDE PARTIES WITHOUT OUR WRITTEN CONSENT.